

OptiT Twist

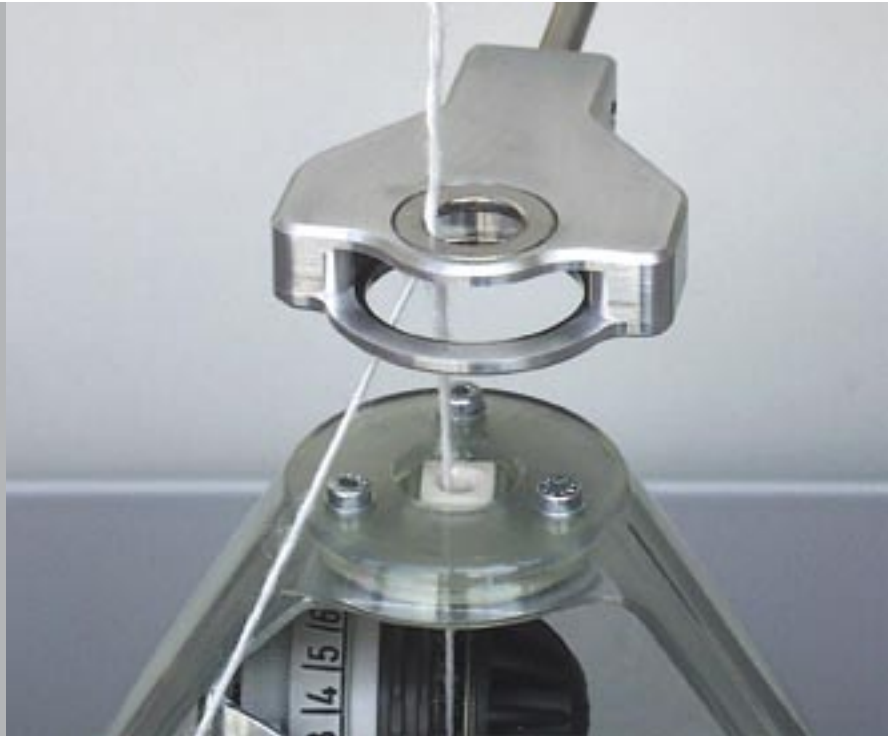

On-line quality control on twisting machines

With OptiT Twist, Barco offers a detector for each individual position, allowing accurate recording of the spindle speed and real time detection of production stops.

Combination with the recording of the delivery speed allows real time monitoring of the twist level. As such, manual checks on the production floor and lab tests are eliminated and a constant quality level is guaranteed. OptiT Twist guards each of the individual components being assembled into a single thread. The breakage of a component is immediately detected.

OptiT Twist can be installed on direct cabling machines or on two-for-one twisters. On two-for-one twisters the diameter of the yarn is checked. This allows detection of knots, slubs, ...

All detectors are connected to a touch screen-based central unit with windows user interface. All information concerning production, efficiency, ends down and slipping spindles is available on the display and can be copied to a USB stick.

BARCO

Visibly yours

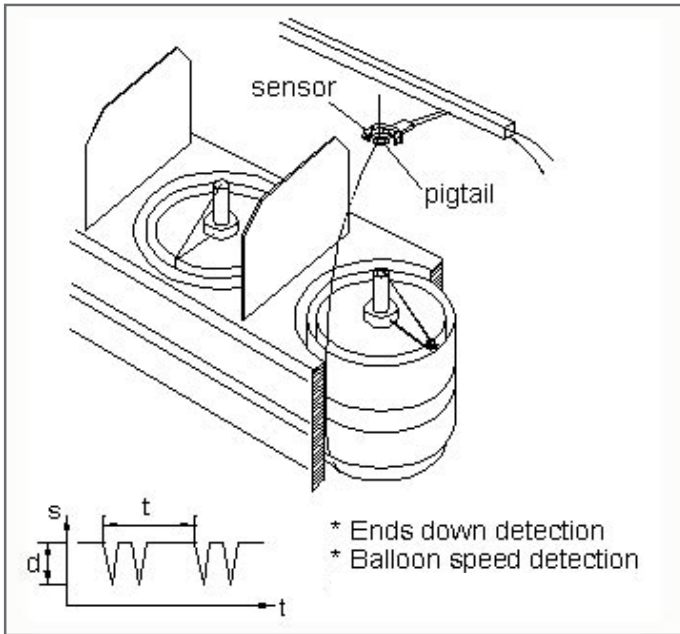

Sensor: Principle of operation

The OptiTwist detector is mounted on the balloon thread guide of the twisting machine. It consists of a photo receiver facing a light emitting diode. During each revolution, the yarn balloon interrupts the light beam twice.

The time between two consecutive interruptions serves as the basis for the calculation of the balloon speed. In combination with the delivery speed, this allows real time yarn twist monitoring and length measurement. The time of each interruption and the amount of light obstructed during the interruption serve as the basis for the yarn diameter indication.

Sensor Control Unit (SCU)

All sensors on one machine are connected to the SCU. This unit offers a touch screen Windows-based user interface, USB interface and Ethernet connection. The integrated OPC server allows a PC to connect to the SCU via the "OptiTwist browser" allowing remote operation and service. The standard screen on the SCU shows a graphical machine view with color coded spindle status and side by side machine details.



TwistMaster monitoring system

Through the OPC interface, all machines equipped with OptiTwist can also be connected to the TwistMaster production monitoring system. All connected twisters are shown in a color coded mill lay-out. Machines with off-standard conditions are automatically flagged.

Functionalities

- Real time yarn breakage detection
- Measurement of spindle and take up speed
- Accurate twist level calculation
- Flagging of spindles with off-standard twist level, with an end down, with yarn defects
- Accurate length measurement
- User friendly interface for set-up and reporting



Benefits

- Prevention of waste by stopping off-quality spindles
- Improved and consistent quality level
- Increased efficiency
- Tracing of defective spindles
- Elimination of laboratory based sampling and stroboscope checks
- Identification of motor and belt problems
- Suitable for all yarn counts
- Simple mounting and cabling
- Low power consumption
- No moving parts, resulting in limited maintenance